

# MCP Indoor Call Point Range

## LED Model

### (Colour Versions)



#### > Product Benefits

- Unique 'Plug & Play' installation concept
- Total 'Flex-Ability' in the choice of operating element
- Anti-Tamper facility
- Enhanced aesthetics
- Backward compatibility



#### Product Overview

Installation efficiency, flexibility and full compliance with the latest standards are at the heart of the new MCP Indoor Call Point range.

Installation time and ultimately cost, are of paramount importance to any fire or security installer. The MCP range directly reflects this need by providing a unique 'plug and play' concept designed specifically to reduce installation time. All new MCP products utilise a special terminal block, where all initial installation cabling is terminated. This terminal block is then simply connected to the back of the MCP. Simple, but effective with no re-termination required and no time wasted.

Both break glass and resettable operating elements can now be used within a manual call point. To provide you with the greatest 'flex-ability', the new MCP range can be configured as either a break glass or resettable unit by simply changing from one element to another. No other additional parts or alternative products need to be ordered.

All MCP Indoor Call Point products also help preserve the integrity of the overall system as illegal removal of the product lid will result in the call point operating and the system going in to alarm.

All MCP2 products are supplied with an LED indicator as standard.

The MCP2A Product version is supplied with both a resistor and normally open, clean contact electrical options. These options are simply utilised by attaching the terminal block to the required connection in the back of the MCP product. A variety of resistor values are available by request, with 470Ω offered as standard.

All of our colour products can be supplied with a variety of markings to meet your specific requirements. Please contact our sales team for further information.

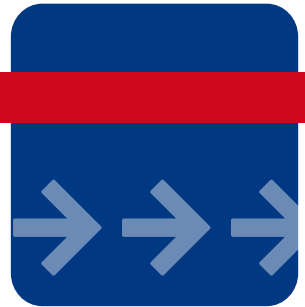



## Electrical Specification

Connection Details:	See Figure . 1
Cable Termination:	0.5-2.5mm <sup>2</sup>
Maximum Voltage:	30VDC
Current Rating (switch only):	2 Amps

Figure .1  
MCP2A-X

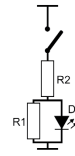

## Environmental Specification

Humidity:	0-95% non-condensing
Operating Temperature:	-10°C to +55°C
Storage Temperature:	-10°C to +55°C
Ingress Protection (IP) Rating:	IP24D

## Mechanical Specification

Material:	PC/ABS
Weight:	110g Flush 160g Surface
Colour:	Green, White, Yellow, Blue.

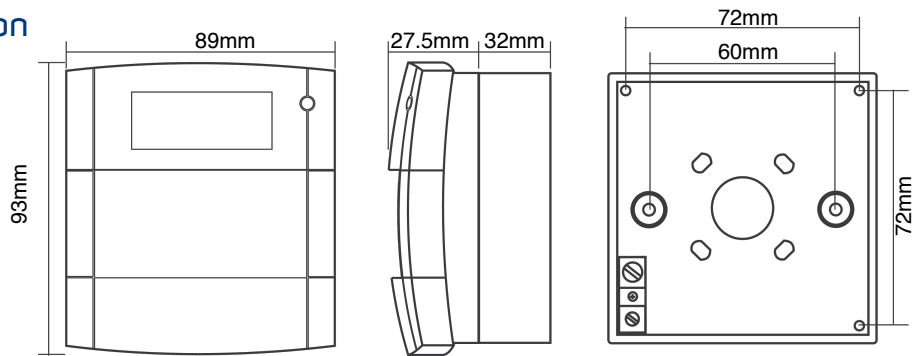

## Ordering Information

Model	Electrical Configuration	Colour	Mounting Element	Operating	Markings
Non-Stock					
MCP2A-G470SG-11	LED, 470Ω Resistor N/O contacts 30VDC	Green	Surface	Glass	PLAIN
MCP2A-Y470SG-11	LED, 470Ω Resistor N/O contacts 30VDC	Yellow	Surface	Glass	PLAIN
MCP2A-W470SG-11	LED, 470Ω Resistor N/O contacts 30VDC	White	Surface	Glass	PLAIN
MCP2A-B470SG-11	LED, 470Ω Resistor N/O contacts 30VDC	Blue	Surface	Glass	PLAIN
MCP2A-G470SF-11	LED, 470Ω Resistor N/O contacts 30VDC	Green	Surface	Flexi	PLAIN
MCP2A-Y820SF-11	LED, 470Ω Resistor N/O contacts 30VDC	Yellow	Surface	Flexi	PLAIN
MCP2A-W470SF-11	LED, 470Ω Resistor N/O contacts 30VDC	White	Surface	Flexi	PLAIN
MCP2A-B470SF-11	LED, 470Ω Resistor N/O contacts 30VDC	Blue	Surface	Flexi	PLAIN

N/O = Normally Open Contact

### Accessories

Code	Description
SC070	Pack Of Ten Test Keys
KG1 x5	Pack Of Five Glass Elements
PS210	Flexible Operating Element
PS200	Plain Hinged Cover
SC071	Pack Of Ten Terminal Blocks

> KAC Alarm Company Limited  
 15 - 19 Trescott Road,  
 Smallwood, Redditch,  
 Worcestershire B98 7AH.  
 England.  
 Telephone: +44 (0) 1527 406655  
 Fax: +44 (0) 1527 406677  
 e-mail: marketing@kac.co.uk